

**Space-saving Two-wire Signal Conditioners B-UNIT**

**INPUT LOOP POWERED ISOLATOR**

MODEL **BSN**

**MODEL & SUFFIX CODE SELECTION**

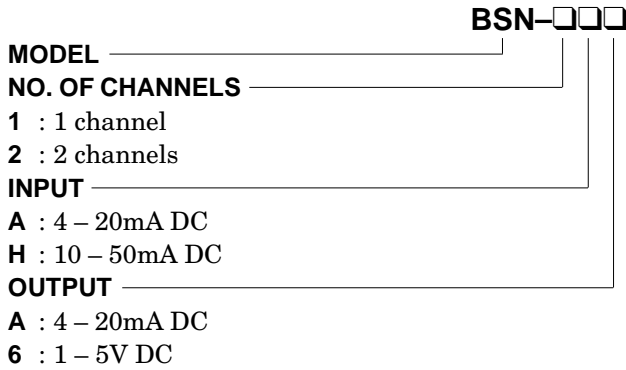

**ORDERING INFORMATION**

Specify code number. (e.g. BSN-2AA)

**GENERAL SPECIFICATIONS**

**Construction:** plug-in

**Connection:** M3.5 screw terminals  
(nickel-plated steel; torque  $\leq 0.8$  N·m)

**Housing material:** flame-resistant resin (black)

**Isolation:** input to output, between channels

**Front adjustments**

**Voltage output:** zero and span;  $\pm 5\%$

**Current output:**  $\pm 0.5\%$  for zero;  $\pm 1.5\%$  for span

**INPUT & OUTPUT**

■ **INPUT 4 – 20mA DC / OUTPUT 1 – 5V DC**

**Equivalent input impedance:** approx. 250 $\Omega$  with 20mA input

**Operational range:** 3 – 22mA DC  
(Accuracy is assured within 4 – 22mA)

**Load resistance:** 50k $\Omega$  minimum

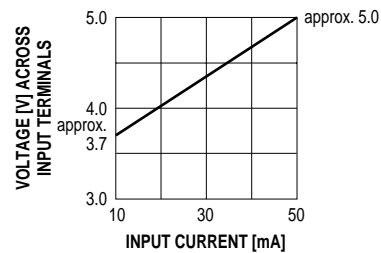
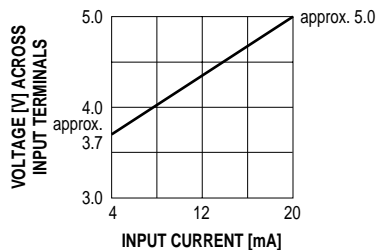

■ **INPUT 4 – 20mA DC / OUTPUT 4 – 20mA DC**

**Equivalent input impedance:** 230 $\Omega$  plus load resistance with 20mA input

**Operational range:** 3 – 22mA DC  
(Accuracy is assured within 4 – 22mA)

**Load resistance:** 350 $\Omega$  maximum; min. 50 $\Omega$  required for adequate operation

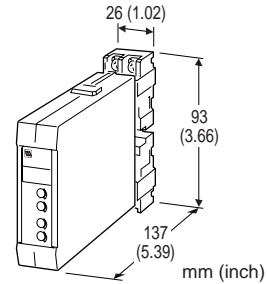
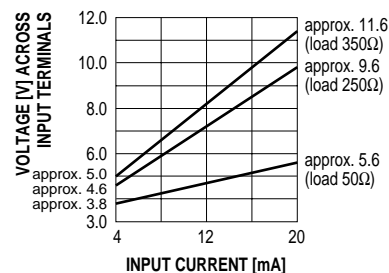

**Functions & Features**

- Loop-powered design eliminates output loop power supply
- 500V DC input-to-output isolation
- 2 isolators housed in one enclosure
- 350 $\Omega$  output drive with 4 – 20mA
- High-density mounting

**Typical Applications**

- Isolation between control room and field instrumentation, between telemetering system and input device
- Eliminates ground problems in existing systems thanks to easiness of application without requiring additional power wiring

■ **INPUT 10 – 50mA DC / OUTPUT 1 – 5V DC**

**Equivalent input impedance:** approx. 100 $\Omega$  with 50mA input

**Operational range:** 7 – 55mA DC  
(Accuracy is assured within 8 – 55mA)

**Load resistance:** 50k $\Omega$  minimum

**INPUT 10 – 50mA DC / OUTPUT 4 – 20mA DC**

Equivalent input impedance:  $90\Omega + [\text{load resistance} \times 0.16]$  with 50mA input

Operational range: 7 – 55mA DC

(Accuracy is assured within 8 – 55mA)

Load resistance: 600Ω maximum; min. 50Ω required for adequate operation

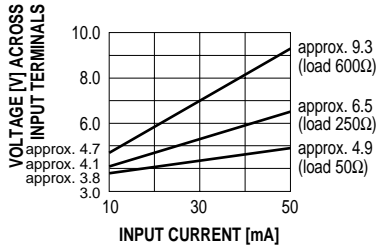

**INSTALLATION**

Operating temperature: -5 to +55°C (23 to 131°F)

Operating humidity: 30 to 90% RH (non-condensing)

Mounting: surface or DIN rail; Standard Rack Mounting Frame BX-16H available

Dimensions: W26×H93×D137 mm (1.02"×3.66"×5.39")  
See General Spec. Sheet Figure A.

Weight: 200 g (0.44 lbs)

Terminal assignment: See General Spec. Sheet Figure B-1.

**PERFORMANCE in percentage of span**

**VOLTAGE OUTPUT**

Accuracy: ±0.1%

Temp. coefficient: ±0.015%/°C (±0.008%/°F)

Response time: ≤0.5 seconds (0 – 90%)

Insulation resistance: ≥100MΩ with 500V DC

Dielectric strength: 500V AC @1 minute

(input to output)

1500V AC @1 minute (between channels)

1500V AC @1 minute

(input or output to ground)

**CURRENT OUTPUT**

Accuracy: ±0.1%

Temp. coefficient: ±0.02%/°C (±0.01%/°F)

Response time: approx. 15 milliseconds (0 – 90%)

Load effect\*

4 – 20mA input: 0.015%/Ω (50 – 150Ω)

0.003%/Ω (150 – 350Ω)

10 – 50mA input: 0.015%/Ω (50 – 100Ω)

0.003%/Ω (100 – 600Ω)

Insulation resistance: ≥100MΩ with 500V DC

Dielectric strength: 500V AC @1 minute

(input to output)

1500V AC @1 minute (between channels)

1500V AC @1 minute

(input or output to ground)

\*The unit is calibrated with 250Ω load at the factory.

**SCHEMATIC CIRCUITRY & CONNECTION DIAGRAM**

Remark: For the single-channel model, the terminals 3 – 4 and 7 – 8 are used.

**VOLTAGE OUTPUT**

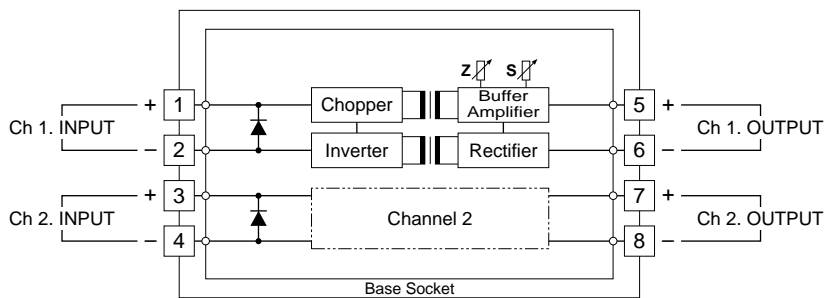

**CURRENT OUTPUT**

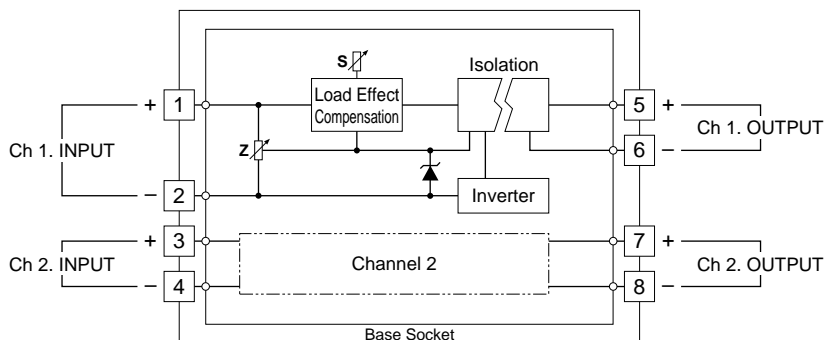

Specifications subject to change without notice.